

DRAWING MADE IN THIRD ANGLE PROJECTION
 THIS DRAWING IS UNPUBLISHED. RELEASED FOR PUBLICATION
 © COPYRIGHT 19 BY AMP INCORPORATED. ALL INTERNATIONAL RIGHTS RESERVED.

LOC	DIST	P	F	ZONE	LTR	DESCRIPTION	DATE	APPD
AJ	16					D REDWN, REV & ADD 2--8 PER AJ-4560	2-20-91	BAS
						E REV PER AJ-5802	11-12-91	JL

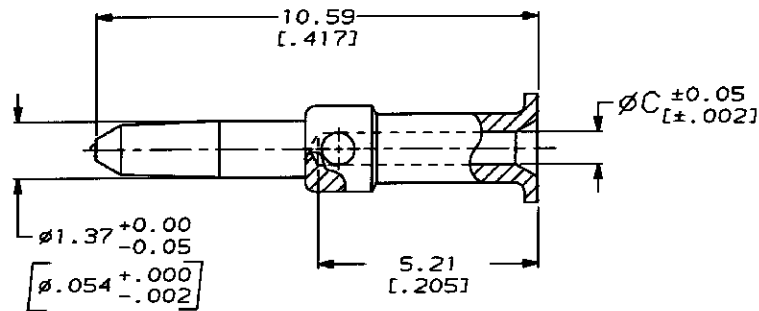

VIEW X

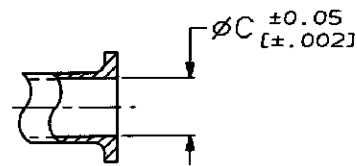

VIEW Y
 SAME AS VIEW X EXCEPT
 FOR DIMENSIONS SHOWN

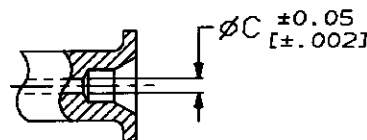

VIEW Z
 SAME AS VIEW X EXCEPT
 FOR DIMENSIONS SHOWN

- ① BRASS PER QQ-B-626
- ② GOLD PLATE PER MIL-G-45204
1.27 μm [0.000050] MINIMUM THICK
- ③ GOLD PLATE PER MIL-G-45204
0.76 μm [0.000030] MINIMUM THICK
- ④ GOLD PLATE PER MIL-G-45204
2.54 μm [0.000100] MINIMUM THICK
- ⑤ SILVER PLATE PER QQ-S-365
2.54 μm [0.000100] MINIMUM THICK

X	0.79 [0.031]	④	2-331352-8
X	0.99 [0.039]	⑤	2-331352-7
X	0.79 [0.031]	⑤	2-331352-6
Z	0.36 [0.014]	③	2-331352-5
X	0.79 [0.031]	④	2-331352-3
X	1.09 [0.043]	③	2-331352-2
Y	1.40 [0.055]	③	2-331352-0
X	0.99 [0.039]	③	1-331352-7
X	1.19 [0.047]	③	1-331352-6
X	0.46 [0.018]	③	1-331352-4
X	0.61 [0.024]	③	1-331352-2
X	0.79 [0.031]	②	1-331352-0
VIEW	C	FINISH	PART NUMBER

			PART NO		
DO NOT SCALE PRINT. UNLESS SPECIFIED DIMENSIONS IN mm [INCHES] TOLERANCES ON: 2 PLC DEC ± 0.20 [0.008] 3 PLC DEC ± - ANGLES ± 5°	DR 2-20-91 B. SCOTT	AMP Incorporated Harrisburg, PA 17105-3608	NAME		
MATERIAL	CHK 3-18-91 J. LIPPERT		CONTACT, MALE, DUAL CRIMP, SERIES BNC		
FINISH	APPD 4-3-91 H. PHILLIPS		SIZE	CAGE CODE	DRAWING NO
SEE TABLE	APPD 4-3-91 J. LIPPERT		③	00779	331352
	PRODUCT SPEC	SCALE	10:1	SHEET	1 OF 1
	APPLICATION SPEC	CUSTOMER DRAWING			
	WEIGHT				